

Measuring cable system distortion

How to comply with FCC regulations

By Bill Morgan, Product Engineer, CaLan Inc., a subsidiary of Hewlett-Packard

Editor's note: Last year, the NCTA revised its Recommended Practices for Measurements on Cable Television Systems to reflect new technical standards imposed by the Federal Communications Commission. This is the fifth installment of a series of articles that focus on specific test parameters to explain how and why they are performed.

The distortion section of the NCTA Recommended Practices thoroughly discusses the process and philosophy of measuring distortions in a broadband network. The intent here is to focus on some key points of the NCTA document and hopefully provide additional insight.

FCC requirement

Section 76.605 (a)(8) says that "the ratio of visual signal level to the rms amplitude of any coherent disturbances such as intermodulation products, second and third order distortions or discrete-frequency interfering signals not operating on proper offset assignments shall be as follows:

- "(i) The ratio of visual signal level to coherent disturbances shall not be less than 51 dB for noncoherent channel cable television systems, when measured with modulated carriers and time averaged; and
- "(ii) The ratio of visual signal level to coherent disturbances which are frequency-coincident with the visual carrier shall not

be less than 47 dB for coherent channel cable systems, when measured with modulated carriers and time averaged."

In other words, the visual carrier must be at least 51 dB above any interfering signals, except (there is always an "except") in a system with harmonically related carriers (HRC). In an HRC system, the visual carrier must be at least 47 dB above the distortion product that falls at the visual carrier frequency (composite triple beat or CTB). This higher level of distortion is allowed because the synchronous nature of the CTB in an HRC system is less objectionable to the viewer than the asynchronous beat in a non-HRC system.

Test requirements

The intent of this measurement is to accurately measure the visual carrier level, and then just as accurately measure the average power of the distortion products in the visual bandwidth. The difficult part of the measurement is accurately determining the level of the distortion products in the presence of noise and video modulation.

The FCC Technical Standards [76.605(a)(8)] specify the distortion performance at the output of the subscriber's terminal. This makes good sense because poorly designed convertors or excessively high levels can contribute to the distortion. One statement in part 76.601(c)(1) which often gets overlooked reads:

"The measurements may be taken at convenient monitoring points in the cable network: Provided, that data shall be included to relate the measured performance of the system as would be viewed from a near-by subscriber terminal."

This statement leads to the understanding that "good engineering practice" will allow creative methods to be used to make these measurements, as long as the results can be related to the performance at the subscriber's terminal. From a practical standpoint, what the FCC is trying to accomplish with these specifications is the guarantee that your system exceeds the minimum performance standards. If the measurement technique is based on sound engineering principles, a repeat of the tests by more traditional test methods will provide the same answers.

It is extremely difficult to measure distortion through the convertor because of the low signal levels available and the signal processing that occurs in many convertors. In consideration of this, the NCTA engineering committee took the approach of measuring the set-top convertor's performance independently and combining it mathematically with the distortion measured at the system test points. When done properly, this method will do an excellent job of relating the measurement to the output of the subscriber's terminal.

Interruptions vs. non-intrusive

The most accurate method for measuring distortion requires the removal of the video modulation for CSO and the removal of the visual carrier for CTB. Because

Figure 1: Distortion - test equipment setup

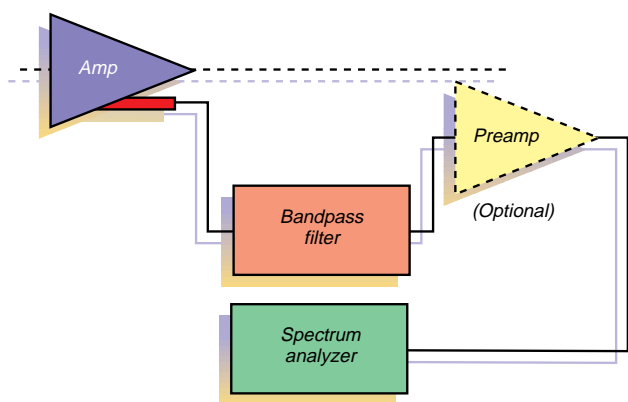
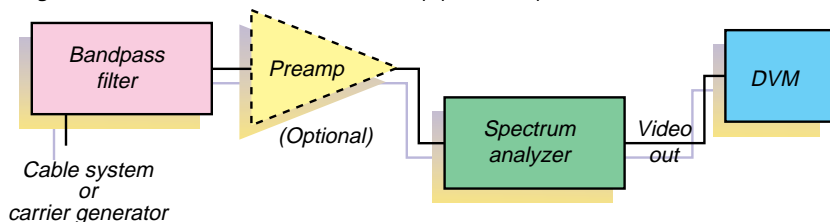
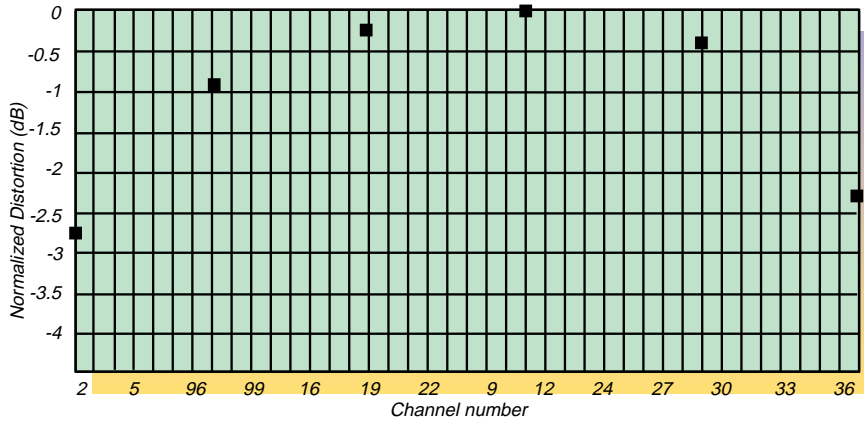

Figure 2: Third order distortion alternate test equipment setup



◆ BACK TO BASICS

Figure 3: Typical normalized system distortion vs. channel



of the necessity of eliminating service interruptions, the approach of the NCTA engineering committee was to provide methods of measurement which will minimize, and if possible, eliminate these interruptions. It is highly recommended that every effort be made to become comfortable with a procedure for this test which will not require signals to be taken off the air.

Three measurement methods are discussed in the NCTA Recommended Practices. Method 1 is the traditional process which requires removing the video modulation for CSO and the visual carrier for CTB. This is the most accurate method but requires a service interruption for both measurements.

Method 2 is an alternate method which uses a CW

carrier and measures the AM modulation component on the carrier. This AM component corresponds to the CTB which is at the carrier frequency. The advantage of this method is that it does not require removing the carrier at the headend, but it still requires the removal of video modulation on the channel under test.

Method 3 eliminates the need to disrupt an active channel by measuring the distortion in an unused portion of the band and extrapolating this reading to the portion of the frequency band with the worst performance. The accuracy of this approach is dependent upon the accuracy of the system distortion characterization. It is less accurate than other methods, but when used with cushion for error, serves as an acceptable method for guaranteeing compliance.

In all three methods, the NCTA Recommended Practices provides a step-by-step approach which will not be repeated here. Instead, this article will address a few additional items. A new method (Method 4) will be presented which has recently been introduced in several new pieces of automated test equipment. For more information on the details of the procedures, please refer to the NCTA Recommended Practices.

Method 1

See Figure 1 to view the distortion test equipment set-up. Then take the following steps:

- 1) Measure the peak level of the visual carrier level
- 2) Remove the video modulation for CTB or remove the visual carrier for CSO

Ad Index

	Reader Service #	Page #
ABC Cable Products	39	70
Alpha Technologies.....	9	19
Alpha/Johnson Controls	22	45
American Lightwave Systems.....	15	29
ANTEC	10, 34, 49	21, 64, 102
Arrowsmith Technologies	35	65
AT&T Network Systems.....	1	2-4
AT&T Microelectronics	36	67
Belden.....	43	77
C-COR Electronics.....	23, 47	47, 90
Cable Prep/Ben Hughes	38	69
Channell Commercial.....	20, 21	42, 43
CONTEC	48	101
Corning.....	37	68
Drake, R.L. Co.	24	49
Fujitsu Network Transmission Sys.	27	52-53
General Instrument.....	28	55
HP CALAN.....	40	71
Hewlett Packard	14	27
Lectro Products	11	23
Line Ward.....		Card Insert
Moore Diversified Prods.	3	7
NCTI.....	29	56
Northern Telecom	6, 32	12-13, 61
Philips Broadband	30	57
Pirelli Cables North America- Communications Division.....	46	80
Qintar	44	78
Riser-Bond Instruments.....	31	58-59
S.A. Canada/Nexus	17	35
Scientific-Atlanta.....	33	63
Sencore	8	17

	Reader Service #	Page #
Siecor.....	12, 45	25, 79
Sprint North Supply	7	15
Standard Communications	4	9
Sumitomo	2	6
Superior Electronics	41	73
Tektronix	42	74-75
Times Fiber	19	41
Trilogy.....	16	33
Tulsat.....	25, 26	50, 51
Tyton Corp.	13	26
Vela Research.....	18	37
Wavetek.....	5	11

Product Showcase

Arrow Fastener.....	105	82
Avcom of Va.	114	85
Budco.....	100	81
Cable Link.....	101	81
DH Satellite.....	103	82
Dynatech.....	106	83
Eagle Comtronics	117	85
FONS Corp.....	110	84
Great Lakes Data.....	104	82
Jerry Conn Associates, Inc.....	108	83
Leightronix	111	84
Lode Data	107	83
Powertronics.....	112	84
Ripley Company.....	116	85
Reliance/CommTec.....	109	83
RMS Electronics	113	84
Time Mfg.....	102	82
Trilithic, Inc.....	115	85

3) Measure the average value of the distortion products.

This approach will always get the most accurate and repeatable results because the masking signals in the band of interest are eliminated. Unfortunately, it also requires that somebody or something at the headend disables the modulation, and/or carrier, for the duration of the measurement after the carrier reference is stored. Because of the video averaging and slow sweep speed required with the 30 kHz IF bandwidth, this measurement can take up to two or three minutes.

Method 2

See Figure 2 to view the alternate test equipment set-up for third-order distortion. Then take the following steps:

- 1) Record the voltage of the carrier reference level in VDC
- 2) Record the level of the CTB imposed on the carrier in VAC
- 3) The distortion magnitude is:

$$CTB = 20 * \text{LOG} \left[\frac{\text{VOLTS}_{AC}}{\text{VOLTS}_{DC}} \right] + 0.5 \text{ dBc} \quad (1)$$

The biggest advantage of this method is that communication is no longer needed with the headend to turn the carrier off for CTB if a channel is available for a CW carrier. It still requires an inactive channel, and in addition, hum and cross modulation will appear as AM components, and are indistinguishable from the CTB.

Method 3

Method 3 is a three-step process. The first step is to characterize the distortion of the system channel by channel. The second step is to measure the distortion at a frequency in an unused portion of the band. The third step is to extrapolate this measurement to the worst case channel in the system by using the characteristic generated in the first step.

The system characterization is the key to the accuracy of this method. Either Method 1, 2 or 4 may be used to make this initial set of measurements. The characterization requires interruption of service, but only needs to be done once unless the system configuration changes. This must be done for each portion of the system with unique channel loading, system tilts, AML or fiber links, amplifier spacing, etc. The characterization will stay relatively constant until major changes such as hardware layout or signal level changes occur in the system.

Figure 3 is a typical plot of the beat distribution and will not vary significantly from system to system. The plot is normalized to the

worst case distortion by subtracting the worst case value from all others. One plot needs to be generated for CSO, and another for CTB.

Using Method 1, 2 or 4, the distortion is measured at an unused portion of the band. If a CW carrier is required, it may be inserted 6 MHz above the highest visual carrier or at a 6 MHz increment in an unused portion of the band. If the system is well behaved and flat, an adjacent visual carrier may be used as the visual carrier reference. If this approach is used, the result must be adjusted for the difference in system gain and tilt between the frequency of the measured carrier and the frequency of the distortion.

The distortion measured in Step 2 (a negative number) is adjusted by the correction factor from Figure 3 to represent the worst case system distortion. For example, if the distortion measured at channel 37 in Step 2 is -58.3 dBc, the worst case distortion at channel 11

Figure 4: Set-top converter distortion - test equipment setup

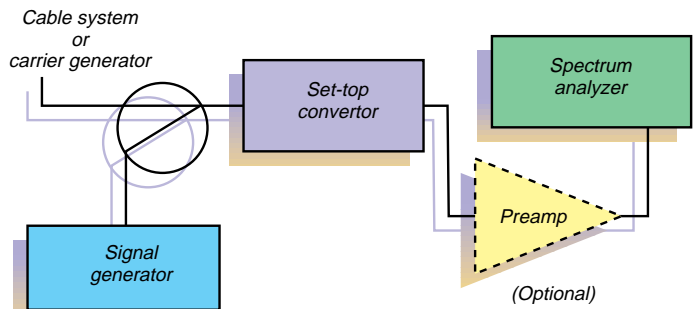

would be:

$$CTB = [-58.3 + 2.2] = -56.1 \text{ dBc} \quad (2)$$

The trade-off of accuracy in this method is offset by the ability to constantly monitor the performance without service interruptions. In order to maintain good engineering practices, the predicted error in this approach must be added to the FCC requirement. For instance, if you suspect this may contain 3 dB of error, then the -51 dBc specification you normally test to becomes -54 dBc to guarantee compliance. If your system is operating close to the limit, then this approach will not have enough accuracy to keep you in a safe zone.

Figure 5: Beat-near-noise correction

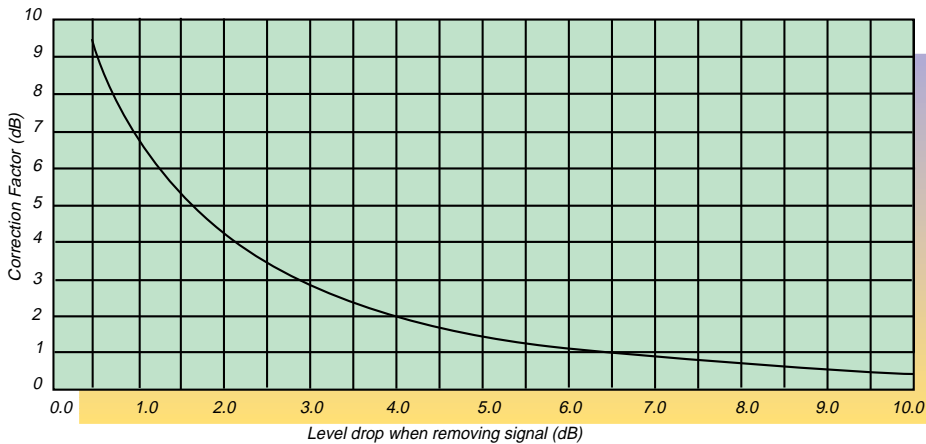

Method 4

Method 4 uses a gated video measurement, which recently became available in some automated test equipment. It allows the measurement of second order components without interruption of service by measuring the distortion during quiet lines in the vertical blanking interval (VBI). It is typically an automated measurement which requires a non-scrambled

channel, but the hardware set-up is the same.

The advantage of this method is that CSO on all unscrambled channels can be monitored automatically without service interruptions. On channels 5 and 6 in a standard channel plan, the CTB component is offset from the visual carrier, allowing CTB to be monitored on these two channels without turning off the carrier.

Measuring the convertor distortion performance by itself is perhaps the most difficult part

of meeting the FCC requirements. Fortunately, the performance of the convertor is typically much better than the system itself and has little contribution to the overall system's distortion performance. The first step is to know whether the convertors are volume control (baseband) or non-volume control (RF) convertors.

In the case of baseband convertors, because of the signal processing on the demodulated video, there is no standard measurement method to recommend. The safest approach is to use specifications provided by the manufacturer. The specifications should be generated using conditions similar to the system operating conditions seen at the subscriber's drop, both in signal level and channel loading. If measurements are required, stick very close to the manufacturer's recommended procedure.

For RF convertors, any procedure used for measuring these should have the approval of the convertor manufacturer, because there are a wide variety of units available. The procedure outlined by the NCTA replaces the normal visual carrier with a carrier offset 250 kHz to 500 kHz below. This keeps the AGC of the convertor operating at a normal level and allows the CTB product to be measured next to the substitute visual carrier. Because of the dynamic range of this measurement (typically >70 dBc), a preamp is necessary between the convertor output and the analyzer input.

Using the set-up in Figure 4 and the visual carrier offset by 250 to 500 kHz, the measurement procedure is the same as Method 1 described in the NCTA procedure.

Calculating set-top distortion

Once the system distortion has been measured at the system test point by any of the methods described, and the performance of the convertors has been established, the two numbers need to be combined to arrive at the FCC requirement. The easiest way to do this is mathematically with Equation 5. You can see from the example that a typical convertor will have less than a 1 dB contribution to the overall performance.

$$\text{Convertor distortion: } \text{DIST}_{\text{CONV}} = -75 \text{ dBc} \quad (3)$$

$$\text{System distortion: } \text{DIST}_{\text{SYS}} = -56 \text{ dBc} \quad (4)$$

$$\text{Combined distortion: } \text{DIST}_{\text{SUB}} =$$

$$20 * \text{LOG} \left[10^{\frac{\text{DIST}_{\text{CONV}}}{20}} + 10^{\frac{\text{DIST}_{\text{SYS}}}{20}} \right] = -55.1 \text{ dBc} \quad (5)$$

Figure 5 provides a graphical approach for combining two distortion values.

◆ BACK TO BASICS

Figure 6: Combining two distortion values

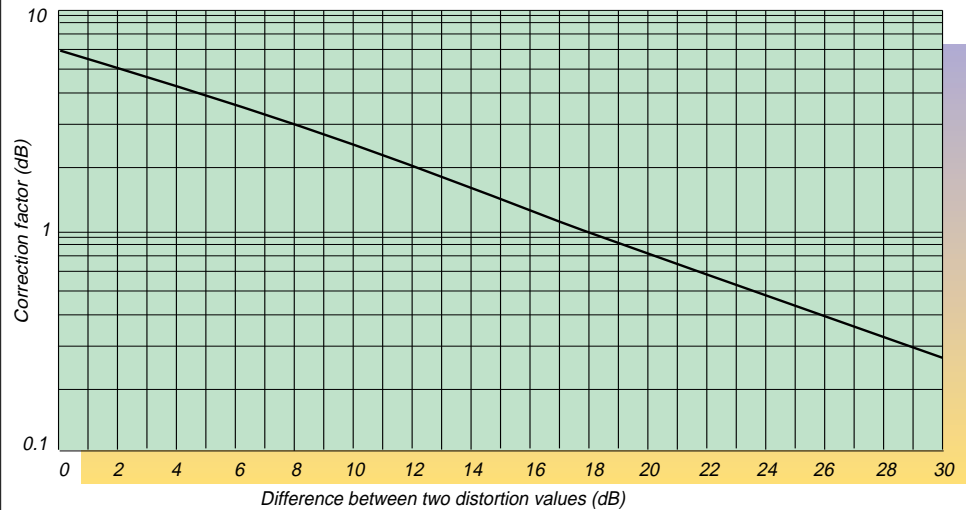

Potential errors

One common error occurs when trying to measure the distortion products near the noise floor of the analyzer. If additional attenuation cannot be removed to provide higher signal level to the analyzer, then a correction factor should be used to adjust the measurement. The easiest way to determine this correction factor is to remove the signal from the input to the analyzer and note the change in level at the beat frequency. Figure 6 plots the correction factor versus this change in level.

Another common error is driving the input of the preamp or analyzer into overload. If this is the case, the system distortion will be masked by the preamp or analyzer distortion. The way to check for this is by increasing the attenuation at the input to the preamp or analyzer by 10 dB and verifying that the distortion changes by only 10 dB. If the distortion products drop by more than 10 dB, you need to start with a lower signal level, or use a bandpass filter at the input to limit the input power.

If a bandpass filter is used to limit the input power, make sure the passband of the filter is flat across the band of use, from the visual carrier to the frequency of the distortion. This can be tricky when using a tunable filter and automatic test equipment. Prior to selecting the automatic measurement mode, adjust the filter by using the noise floor of the analyzer to determine the filter's location.

Test equipment errors

In order to get accurate results in any of the methods discussed above, the errors contributed by the test equipment need to be understood. Because this is a high dynamic range measurement, the most important specification is the log scale fidelity or log scale

linearity. This will usually be specified as x.x dB / 10 dB or a maximum error of x.x dB. One step that is often overlooked is the addition of this error to the measurement limit requirements.

For instance, if the maximum error of the analyzer is 1.5 dB, then the FCC target specification becomes -52.5 dBc instead of -51 dBc. If the attenuator is changed between the measurement of the visual carrier and the measurement of the distortion, then the attenuator accuracy also needs to be considered. This can add another 1.0 dB or more of uncertainty, depending on the quality of the test equipment.

Because of this, it is important to understand the accuracy of the instrumentation. It is conceivable that the potential error could be 3 dB or 4 dB with a lower cost piece of test equipment. It also means that if a higher dynamic range analyzer is used (one that can make the measurement without changing the attenuator), you can eliminate the attenuator uncertainty and lower your target specification.

To verify the accuracy of test equipment (and minimize the uncertainty of the measurement) it's a good idea to verify the log scale fidelity of the analyzer with a precision attenuator. A good attenuator will allow the analyzer's performance to be checked. Remember, this is a comparison measurement between a high level and low level signal, so absolute accuracy is not the concern for this particular test. What is important is that when you step the attenuator 60 dB, the signal on the display changes 60 dB. Log scale fidelity is a performance criteria that will change with operating temperature, so this should be verified across the operating temperature range.

Hopefully, this brief synopsis will make the semi-annual proof tests a little easier. **CEC**